

Post Focus BWA-MON[®]

Post Focus BWA-MON

The BWA-MON **B**eam **W**aist **A**nalyzer **M**ONitor system and software enables “real-time” laser beam measurement, analysis and monitoring of multi-kilowatt CW and pulsed lasers. The system design is based on the international standards ISO 11146 and ISO 13694 which relate to lasers and laser related equipment and laser beam spatial metrics.

In every laser application, the laser beam profile provides valuable information for the most efficient use of the laser. By monitoring the laser beams spatial profile, circularity, centroid, astigmatism and M^2 values, provides early warning of any problems with the laser and entire beam delivery optical system. This relates to increased quality, process reliability, and reduced scrap.

The BWA-MON system is modular in design and can be configured for most applications and laser wavelengths. The design contains no moving components and provides instantaneous measurements and analysis of the laser beam and all active optical elements.

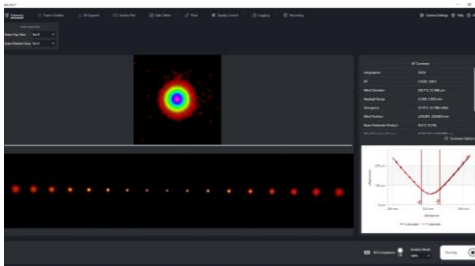

Summary Screen

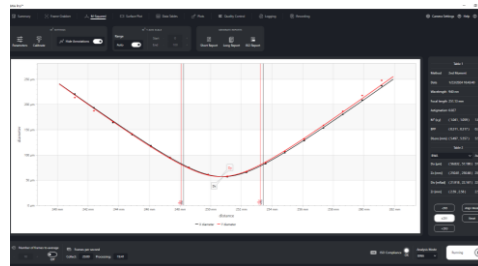

Full Scan Mode ISO Measurement

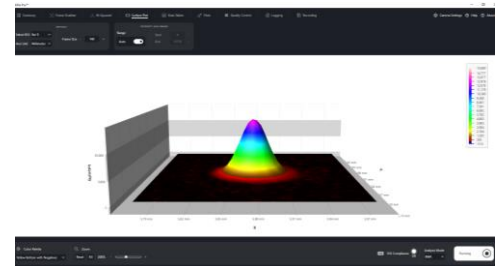

3-D Profile of Beam Waist

The patented[†] BWA-CAM is positioned after a compact attenuation module that reflects < 0.0016% of the light into the unit. The remaining light is passed and absorbed by a high-power beam dump. The beam waist can be seen in the primary region of interest (ROI). The smallest spot is located about midway in the series of spots (see image to the left). Once the multiple spots, each one a spatial cross-section along the beam caustic, are nearly horizontal, the software automatically tracks and sizes the ROIs for accurate M^2 measurement.

BWA-MON configurations available for powers up to 30 kilowatts and fiber core sizes from single mode to 1 mm.

[†]Covered by one or more of the following US patents: 8237922; 8427633; 8619247; 8711343; 8848177; 8848178; 8848179; 10708537; 10942275

Visit our website at www.HAASLTI.com for additional information and product videos

Haas Laser Technologies, Inc | 37 Ironia Road, Flanders, New Jersey 07836 | USA

Ph: (973) 598-1150 | info@haaslti.com

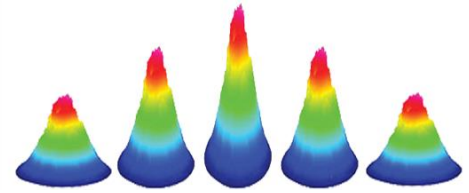

Features

Optical	
M ² Measurement	Real-Time with No Moving Optics or Hardware
Rayleigh Range	1 mm to 48 mm
Single or Dual Camera	M ² measurement with Single or Dual Cameras
Auto Tracking of ROIs	Software Auto Sizes and Tracks all Regions of Interest (ROI)
QC Measurement	All Beam Quality Metrics Monitored and Flagged for External Interlocking Control
Extended Report Generations	ISO Report Generator of all Beam Quality Metrics
Logging & Recording Capability	All Beam Quality Metrics and Record Live Camera Measurements for Offline Playback
Attenuation	-5 to -8 OD Attenuation Built-in
Optional High-Power Attenuator	For Power Levels to 30 kilowatts and above
Alignment	Easy Setup, Alignment and Calibration
Post Focus Spot Size	≥ 2 microns

Specifications

Parameter	Description	Units
Sensor	CMOS, 1/1.1" (4:3)	
Pixel Area	4128 x 3008 Monochrome	
Pixel Size	2.74 x 2.74	μm
Active Sensor Area	11.311 x 8.242	mm
Scanning System	Progressive (Global Shutter)	
Gray Level	12	bits
Frame Rate (in 8-bit mode)	10	fps
Trigger	Auto or External (DIN 8)	
Power Consumption	1.9 – 4.0	W
Interface	POE 1 GigE	
Dimensions (L x W x H)	~ 461.7 x 139.9 x 173.7	mm ³
Weight	~5.31	kg
Temperature Range	0 - 55	°C
Relative Humidity (non-condensing)	20 - 80	%
Wavelengths	350 - 1200	nm
Built-in Attenuation	-5.0 to -8.0	OD

*Power Over Ethernet (POE) Injector or switch, 48V 15.4W Power Over Ethernet, IEEE 802.3af Compliant, 10/100/1000Mbps and Category 5e, 6, or 6a cables only are not included with system.

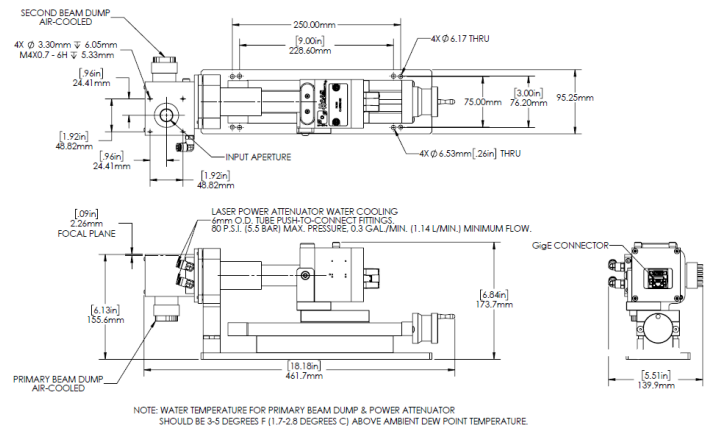

Specifications subject to change without notice. Consult a Haas Laser Technologies engineer (973) 598-1150 for the latest specification changes or any additional assistance. Technical drawings of our products are available at www.haaslti.com. Contact sale@haaslit.com for ordering information.

Visit our website at www.HAASLTI.com for additional information and product videos

Haas Laser Technologies, Inc | 37 Ironia Road, Flanders, New Jersey 07836 | USA

Ph: (973) 598-1150 | info@haaslti.com